



## SERVOCOMANDO DRIVE

### Art.9536 (per art. 2136 e per art. 2137)

#### Descrizione / Description

##### SERVOCOMANDO PER VALVOLE DI ZONA

Il servocomando opera sulla valvola con una rotazione bidirezionale di 90° passando dalla posizione di chiusura (by-pass) alla posizione di apertura e viceversa.

##### DRIVE FOR ZONE BALL VALVE

The drive works on the valve with a 90° bi-directional rotation by moving from the closing position (by-pass) to the opening position and viceversa.



#### Schema elettrico Electrical diagram

1	BLU/BLUE -----NEUTRO, NEUTRAL
2	NERO/BLACK -----CONSENSO CALDAIA,BOILER
3	NERO/BLACK -----CONSENSO CALDAIA,BOILER
4	MARRONE/BROWN -----FASE, PHASE
5	GRIGIO/GREY -----TERMOSTATO AMBIENTE, ROOM THERMOSTAT

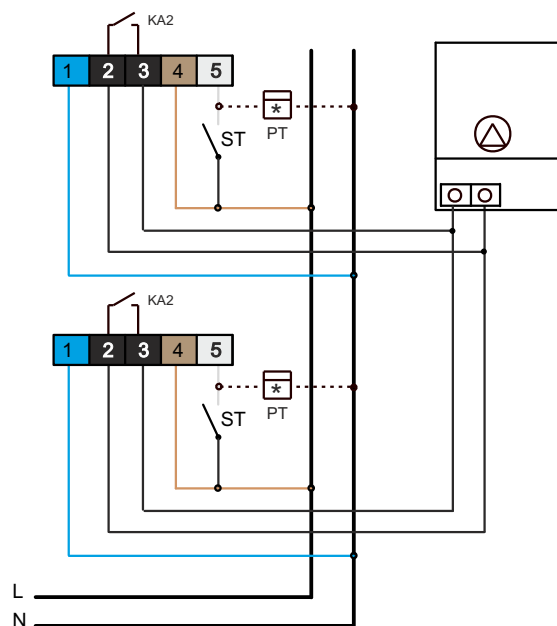

ST = termostato ambiente  
Room thermostat

PT = contaore  
hour counter

#### Caratteristiche Tecniche Technical Features

Alimentazione morsetti 1 - 4 :	a 230Vac o 24Vac(50...60 Hz)
Power supply terminals 1 -4 :	at 230Vac or 24Vac (50...60Hz)
Potenza assorbita	6 VA
Absorbed power	6 VA
Contatto relè morsetti 2 -3 :	pulito (non in tensione)
Contact relay terminals 2 -3 :	attivo a valvola aperta
	dry ( no power)
	close when the valve is open
Grado di protezione	IP 44
Protection degree class	IP 44
Temperatura di esercizio	min -5°C max 55°C
Operating temperature	min -5°C max 55°C
Coppia max di rotazione	8 Nm
Maximum rotation couple	8 Nm
Tempo di manovra	40 sec.
Control time	40 sec.
Fusibile	5x20 F350 mA
Fusing	5x20 F350 mA

#### Dimensioni d'ingombro External dimension

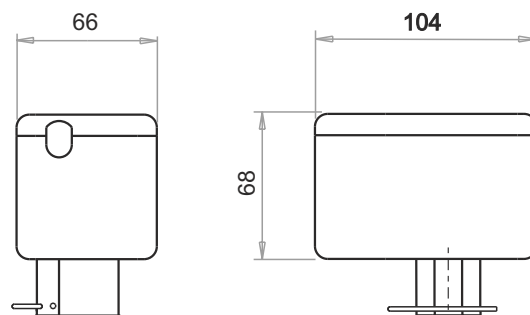

\*Verificare che l'alimentazione corrisponda a quella prevista dalle caratteristiche.  
\*Make sure that the power supply is corresponding to that foreseen by technical characteristics.

\*Trattandosi di un apparecchio di classe II non si deve effettuare il collegamento al conduttore di protezione.  
\*Because it is a class II unit it is not necessary to connect it to a protection conductor.

**TIEMME Raccorderie S.p.A.**  
Via Cavallera 6/A (Loc. Barco) - 25045 Castegnato (Bs) - Italy  
Tel +39 030 2142211 R.A. - Fax +39 030 2142206  
info@tiemme.com - www.tiemme.com